

RAF
100

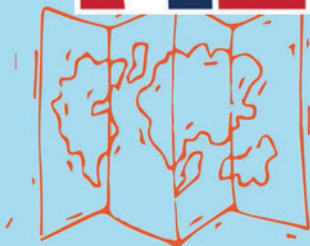

Llyfr Gweithgareddau

CYNRADD



Pen-blwydd Hapus!

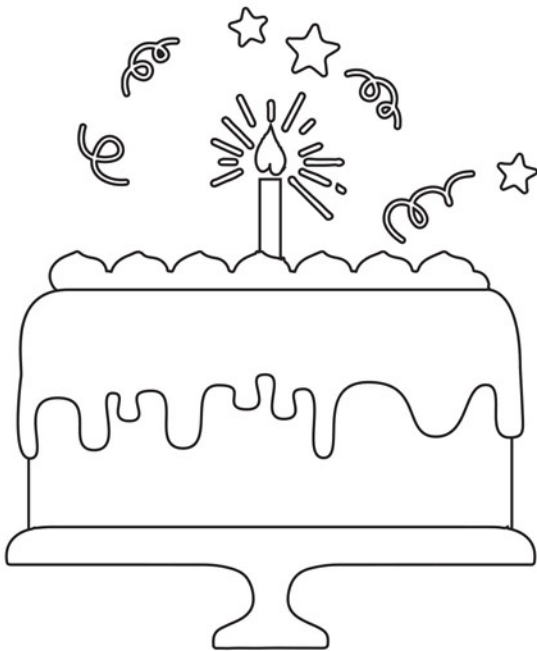

Bydd yr RAF yn 100 oed yn 2018. Dyma'r lluwyr hynaf yn y byd. I helpu i ddathlu, maen nhw wedi gwneud llyfr gweithgareddau i chi.



Cymraeg



Mathemateg

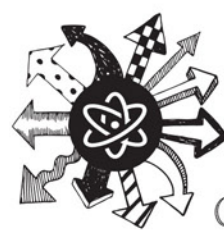

Gwyddoniaeth

Cadwch lygad am y rhain - maen nhw'n dweud pa fath o weithgaredd rydych chi'n ei wneud.



Pan fyddwch chi'n gweld hyn mae'n golygu y gallwch chi liwio'r llun.

Dyma Penny a Peter. Maen nhw'n beilotiaid.
Mae Penny yn hedfan awyren Typhoon, a
Peter yn hedfan hofrennydd Puma.

Allwch chi eu lliwio nhw?

Byddan nhw'n ein helpu ni â rhai o'r gweithgareddau yn y llyfr ...

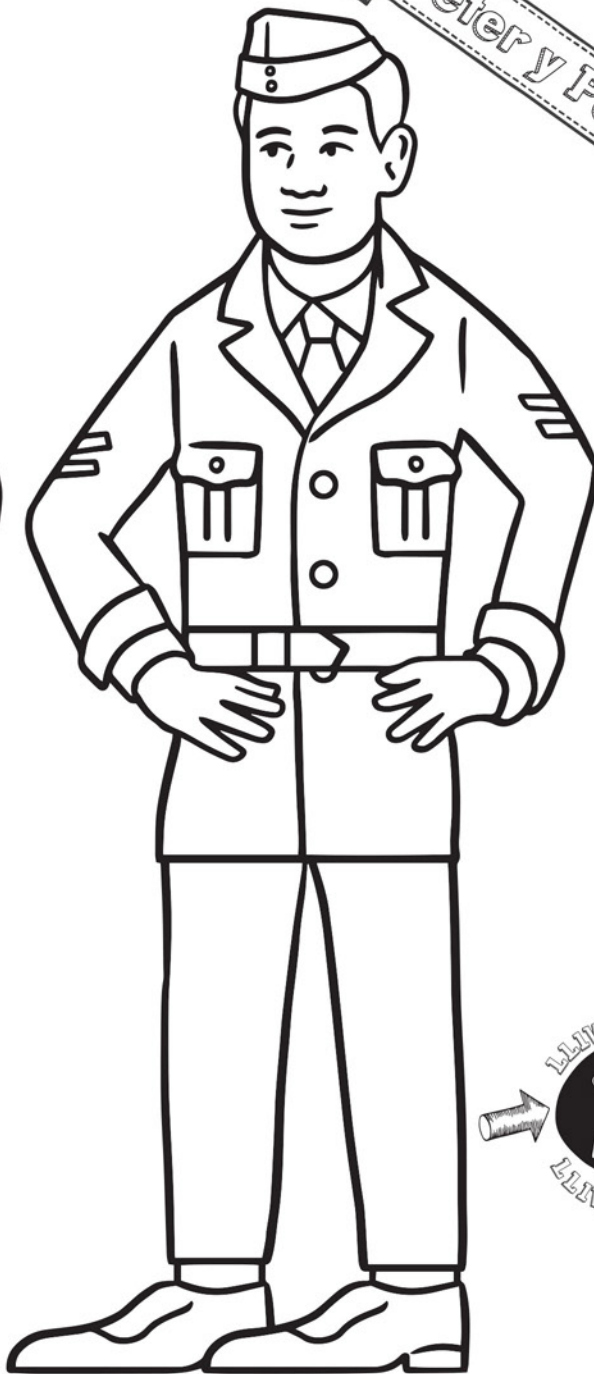
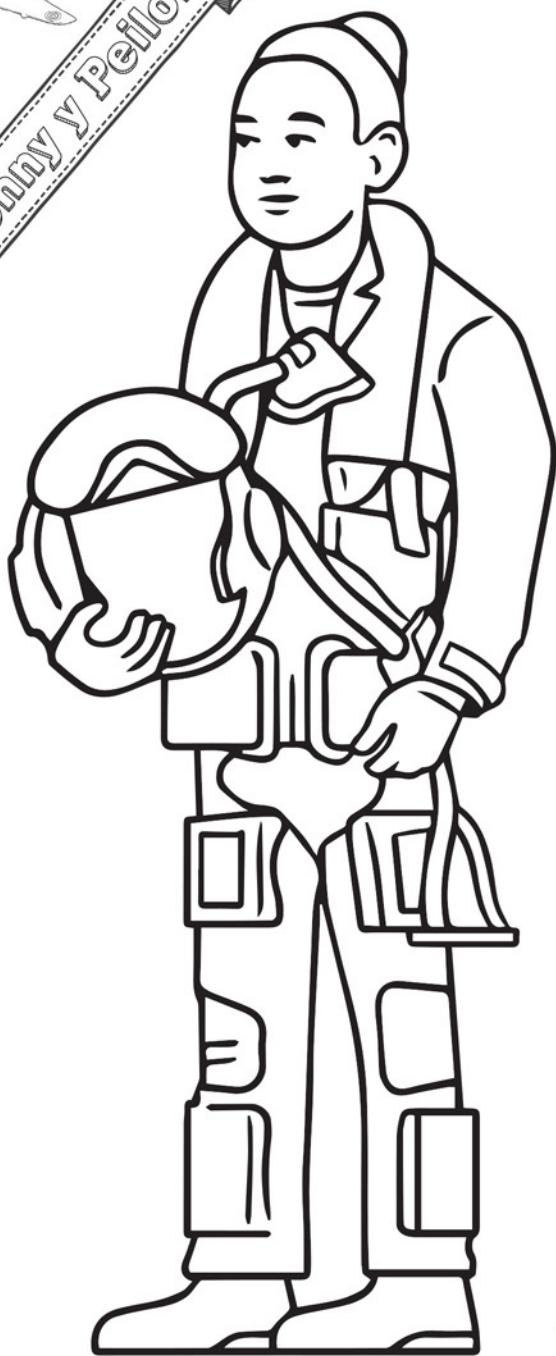
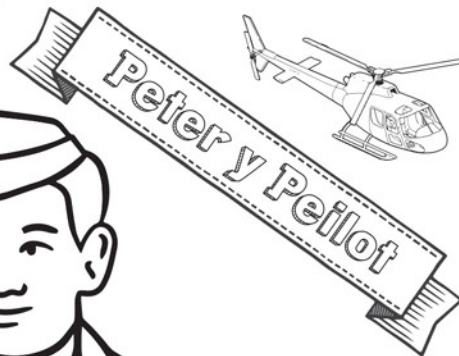
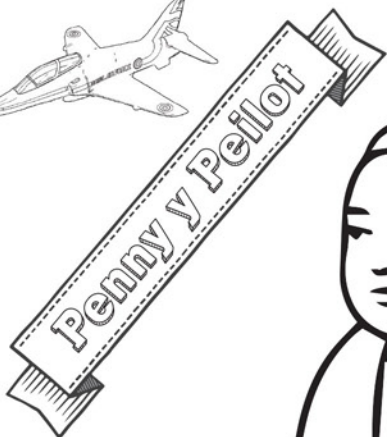
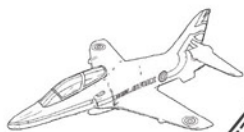



Chwilair



Cymraeg

Z	D	R	E	D	A	R	R	O	W	S	T	H	J	U
P	G	D	M	M	Y	G	V	F	S	P	A	O	Q	U
C	E	A	Y	U	G	R	Y	P	T	B	J	F	J	N
R	E	I	Z	N	W	K	I	Z	C	N	L	R	Z	T
S	Q	E	L	T	N	T	Z	N	M	P	F	E	O	H
N	N	M	D	O	F	A	I	E	O	Z	V	N	Z	L
U	U	O	U	I	T	E	I	C	U	O	G	N	A	B
L	F	K	R	N	Z	I	S	R	X	C	K	Y	M	X
L	O	E	A	F	D	E	H	R	I	Y	Y	D	H	E
W	H	D	H	Y	Z	Q	L	D	V	E	W	D	P	N
A	G	K	A	H	T	Q	J	M	W	I	P	J	L	F
Z	W	O	N	D	V	J	G	A	W	Y	R	E	N	T
X	U	Y	M	B	K	E	W	M	L	I	V	N	V	X
I	T	G	R	U	I	W	S	E	E	K	A	N	L	G

Chwiliwch am y geiriau isod yn y chwilair.

Rhowch gylch am bob gair rydych yn ei weld.

AWYR

AWYREN

MAES

PEIRIANNYDD

PEILOT

SPITFIRE

LLU

HOFRENNYDD

REDARROWS

RHEDFA

TWR



Allwch chi helpu gyda'r rhain

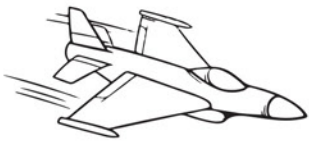

Cymraeg

Llythrennau wedi'u cymysgu

Mae'r llythrennau sy'n ffurfio'r geiriau hyn wedi'u cymysgu, ac mae'r RAF angen eich help chi i'w rhoi nhw yn y drefn gywir i gael gwybod beth yw'r geiriau.

LOTPIE

Cliw: Rhywun sy'n hedfan awyren

EDDIRIANNYP

Cliw: Rhywun sy'n trwsio ac yn adeiladu pethau

DARHEF

Cliw: Llain galed i helpu awyrennau i godi i'r awyr a glanio

NAIAD

Cliw: Rhan o awyren

FFIGART

Cliw: Enw arall am awyrennau yn yr awyr

.....
FRONHENYDD

Cliw: Math o awyren

.....
DICO

Cliw: Rhywbeth mae awyren yn ei wneud er mwyn mynd i fyny i'r awyr

.....
NALOGI

Cliw: Rhywbeth mae awyren yn ei wneud er mwyn dod yn ôl i'r tir





Mathemateg

Awyrennau coll

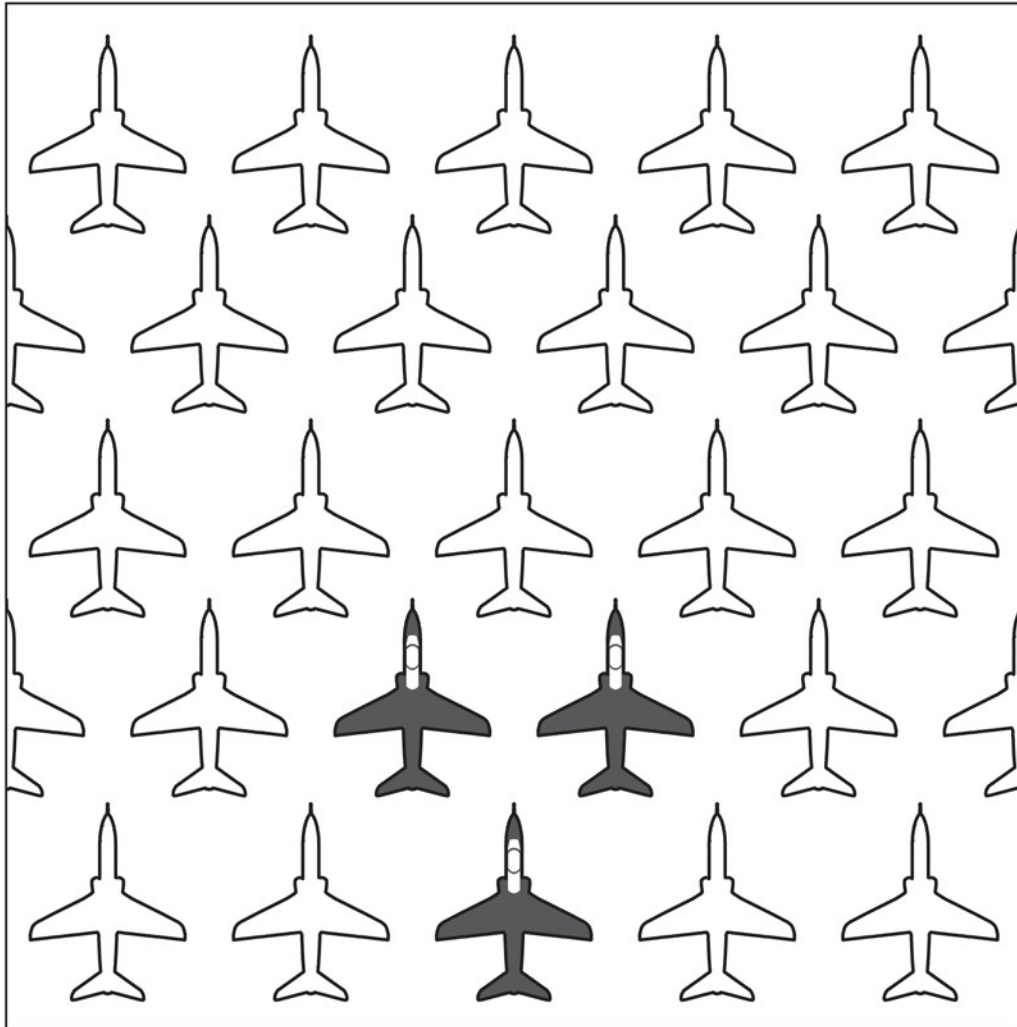

Lliwiwch yr awyrennau coll er mwyn i'r Red Arrows allu hedfan mewn siâp diemwnt.



GLIW!
Mae 9 awyren yn y Red Arrows. Sut allwn ni ychwanegu chwe awyren i wneud iddyn nhw hedfan mewn siâp diemwnt?





Cymraeg

Llythrennau coll

Dyma Angela. Mae hi'n hedfan awyrennau i'r Llu Awyr Brenhinol. Beth yw enw ei swydd? Llenwch y bylchau.

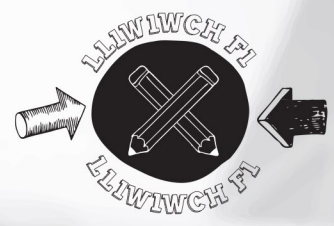

P_i_ot

Beth yw enw ...?

Allwch chi enwi gwahanol rannau o'r awyren?

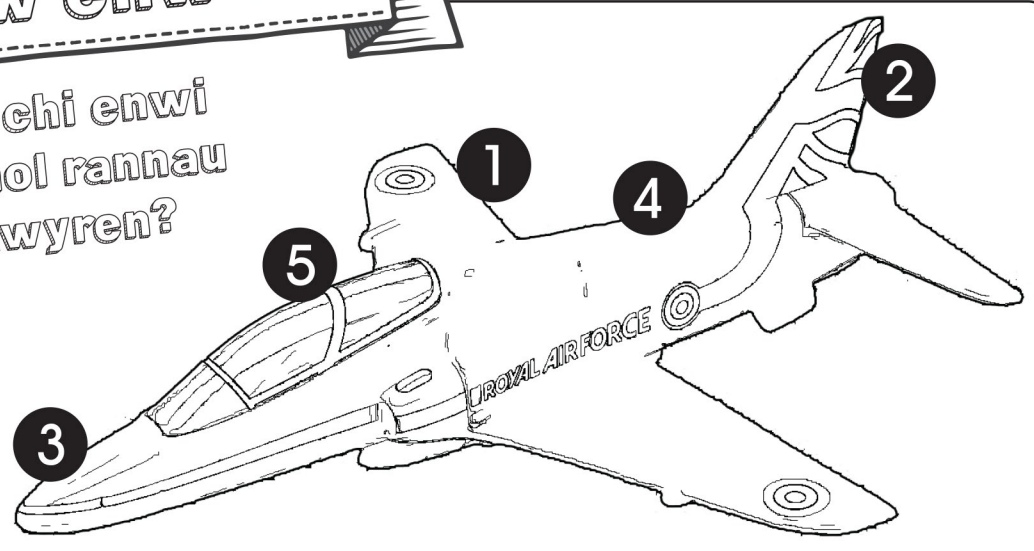
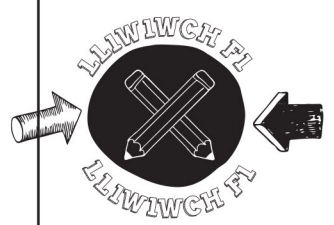

Rhowch y rhif yn ymyl y gair:

- Trwyn
- Adain
- Caban Peilot
- Cynffon
- Corff yr Awyren



Swyddi'r RAF



Cymraeg

Tynnwch linell o enw'r swydd i'r offer sy'n cael eu defnyddio i wneud y gwaith.

Gweithredwr Radar



Peilot

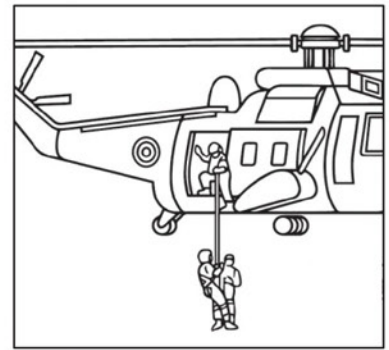

Meddyg/Achubwr

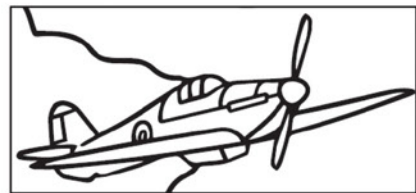

Gwyddonydd
Cyfrifiadurol



Gweithredwr
Cyfathrebu

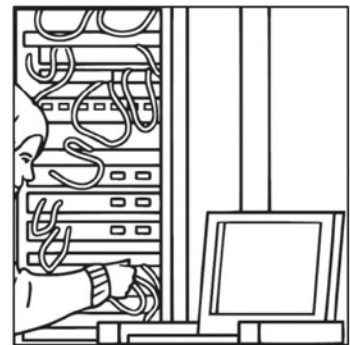

Rheolwr
Traffig Awyr

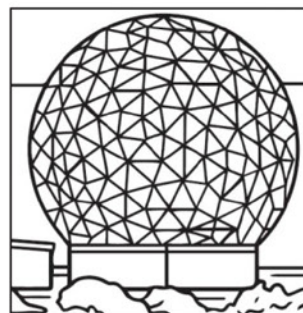



Pellter mwyaf

Gwyddoniaeth

Pa un o'r rhain yw'r un cyflymaf?

Rhowch \checkmark yn y blwch wrth yr un rydych chi'n meddwl sy'n gallu teithio'r pellter mwyaf.

A

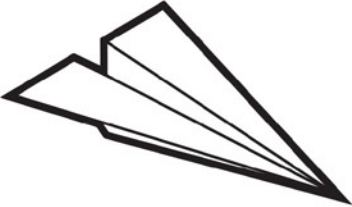

Awyren bapur

B



Roced

C



Balŵn aer poeth

D



Awyren

Gosodwch nhw yn eu trefn (o'r rhai sy'n gallu teithio'r pellter lleiaf i'r rhai sy'n gallu teithio'r pellter mwyaf)

Dyma'r un arafaf

Mae hwn ychydig yn fwy cyflym

Mae hwn dipyn mwy cyflym

Dyma'r un cyflymaf

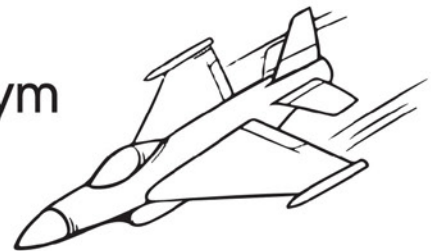

Faint o Olew?

Mathemateg

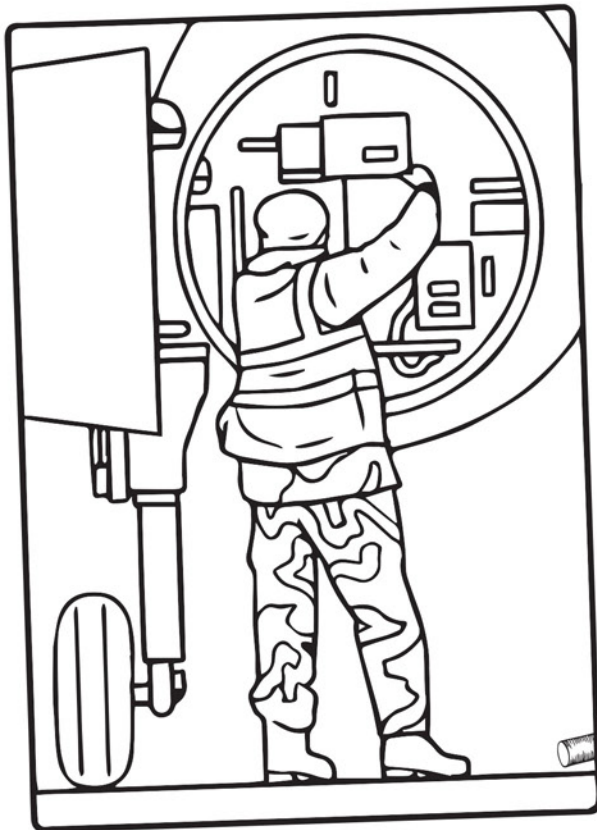

Mae'r peiriannydd RAF hwn wedi defnyddio chwarter yr olew sydd yn ei dun wrth wneud awyren yn barod i hedfan. Os oedd y tun yn llawn cyn iddo ddechrau, lliwiwch yr arwynebedd sydd ar ôl.

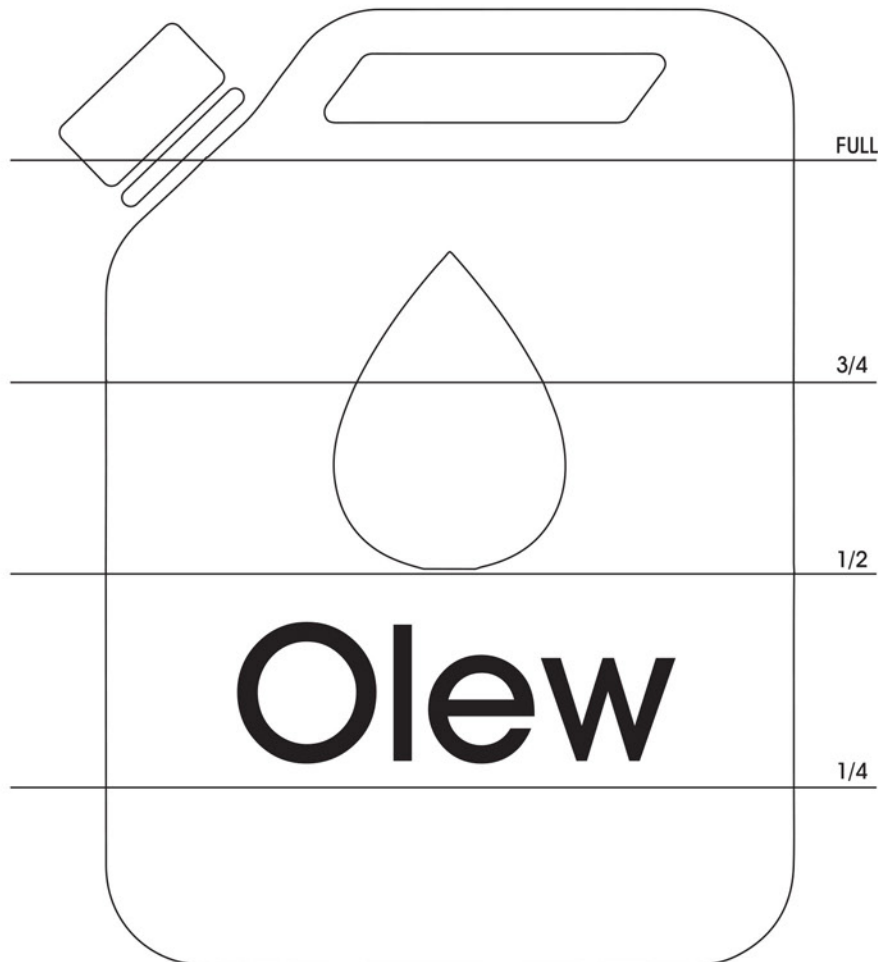

Y Maes Awyr



Cymraeg

Mae'r RAF yn defnyddio eu meysydd awyr arbennig eu hunain i hedfan eu hawyrennau. Maen nhw'n debyg i'r rhai mae pobl yn eu defnyddio pan fyddan nhw'n mynd ar eu gwyliau. Allwch chi gyfateb y lluniau isod â'r geiriau iawn?



Rhedfa
Radar
Pasbort

Tŵr rheoli
Pelydr-x
Tocynnau

Awyren
Bag
Teithiwr

Penny yn hedfan

Mae Penny y Peilot angen help gennych chi!

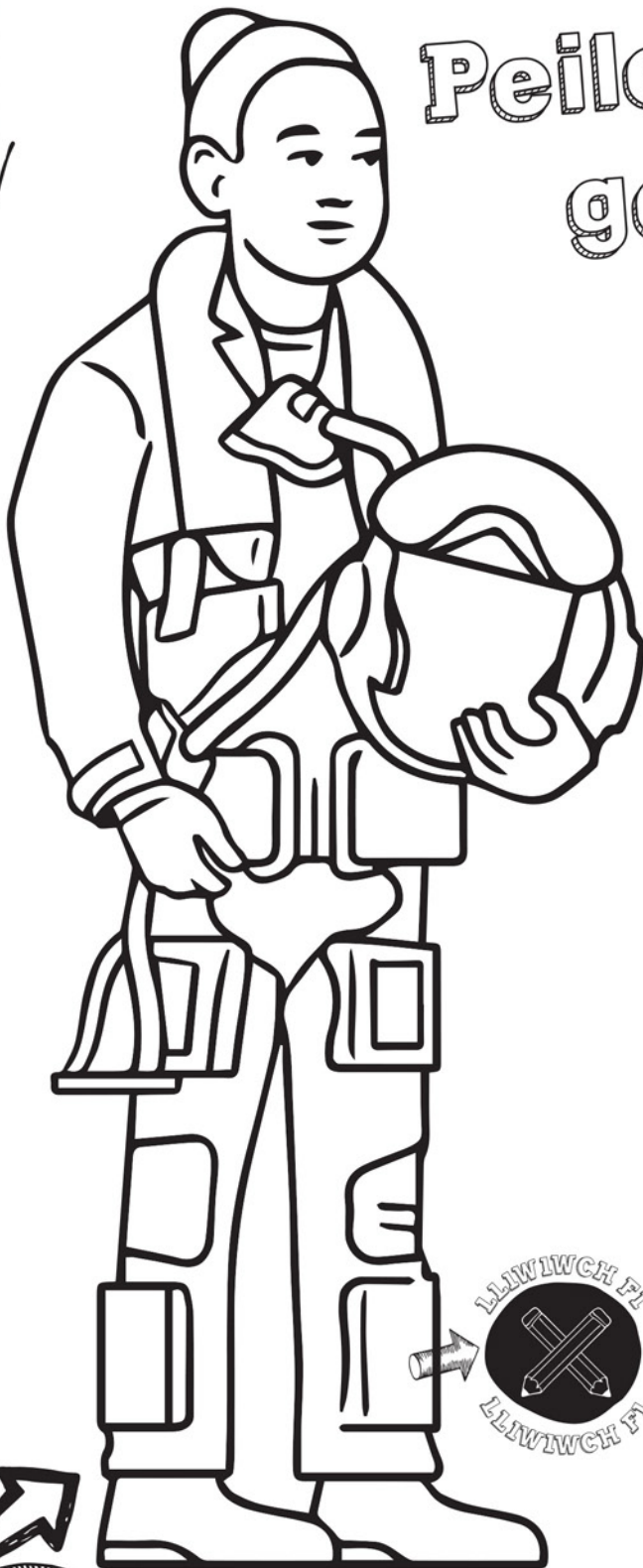

Er mwyn cael digon o danwydd i gwblhau'r daith mae angen i fesurydd y tanc tanwydd gyrraedd y marc 4/5ed. Allwch chi ddweud wrth Penny pa awyren i'w defnyddio drwy edrych ar y mesuryddion tanwydd yma?





Mathemateg

A:

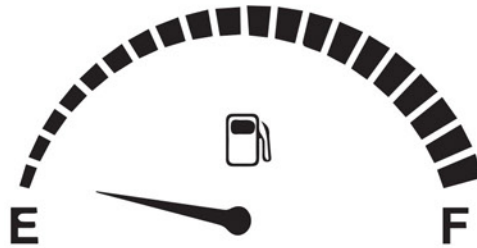

B:



C:

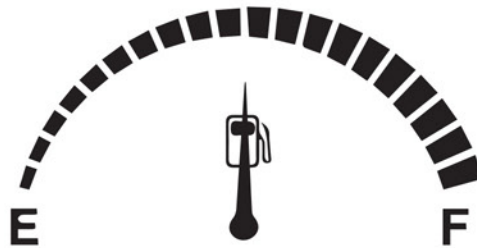

D:



E:

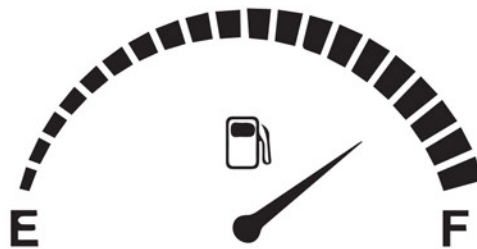

Ysgrifennwch y llythyren yn y blwch hwn i ddangos pa awyren ddylai Penny ei defnyddio (yr un sy'n dangos bod y tanwydd yn y tanc yn cyrraedd y marc 4/5ed)



Cludo bwyd



Mathemateg

Mae'r awyren hon yn cario bwyd. Gall gario digon o fwyd i fwydo 320 o bobl. Faint o awyrennau fyddwn ni eu hangen er mwyn gallu bwydo 1,000 o bobl?



1



= digon o fwyd i 320 o bobl!

Ysgrifennwch yn y blwch hwn faint o awyrennau y byddwn ni eu hangen er mwyn gallu bwydo 1,000 o bobl.

Peilotiaid yr RAF

Allwch chi gyfri faint o beilotiaid sydd yn y llun hwn? Ysgrifennwch y cyfanswm yn y blwch.



Mathemateg

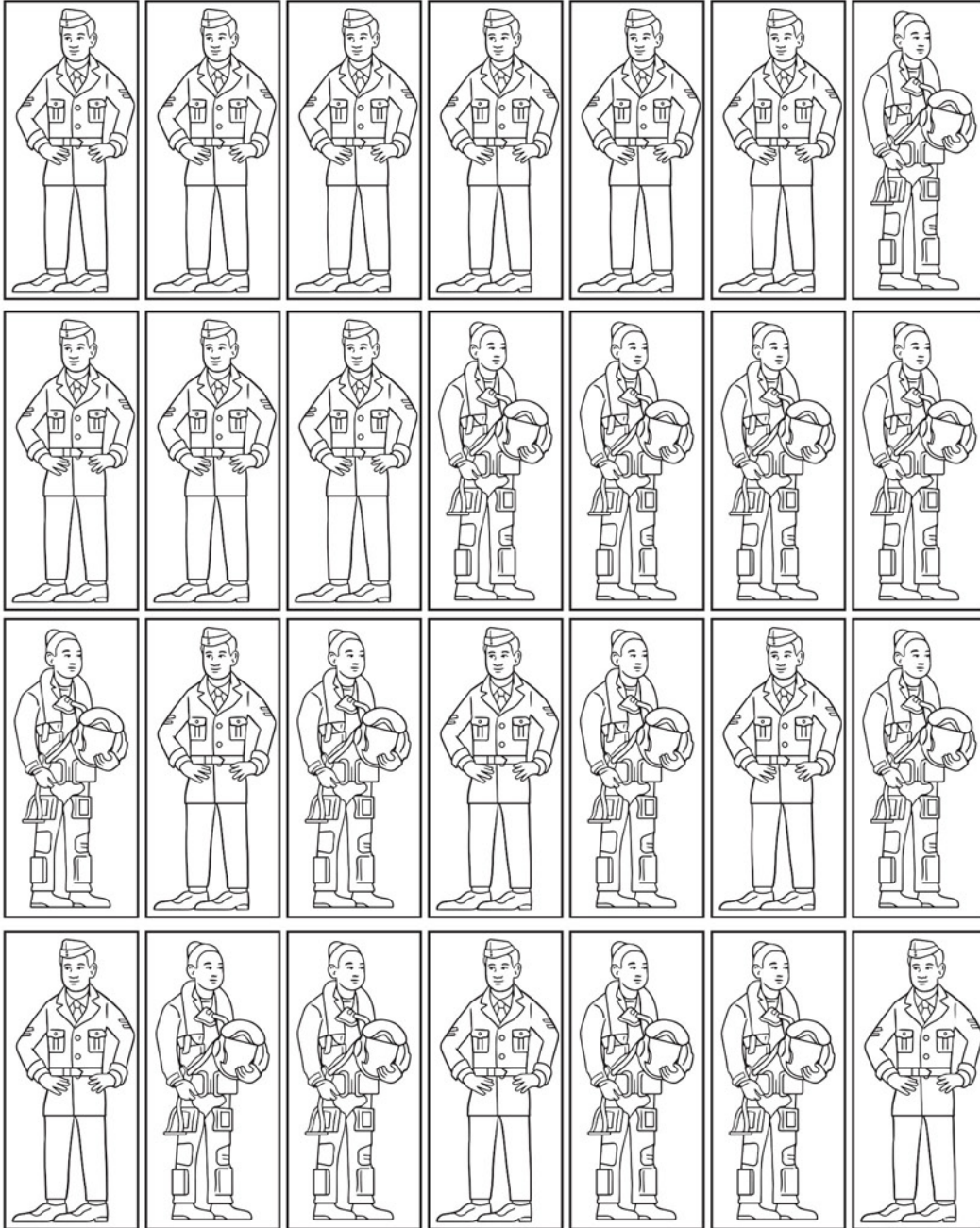

Cyfanswm

Faint o'r Peilotiaid sy'n Ferched?

Faint o'r Peilotiaid sy'n Ddynion?

Pe bai hanner y Peilotiaid yn Ferched, faint ohonyn nhw fyddai yna?



Mathemateg

Cartrefi i hofrenyddion

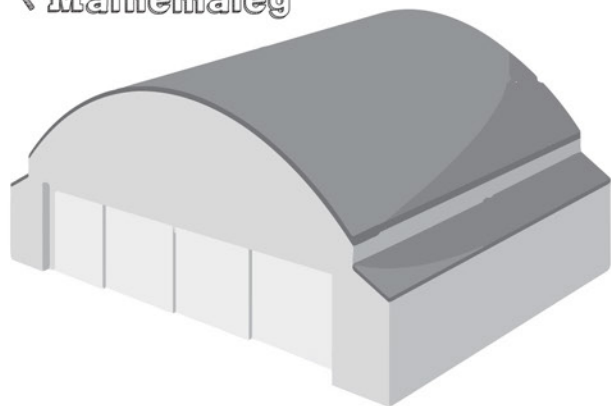

Dyma lun o hangar awyrennau. Mae hofrenyddion yn cael eu cadw mewn hangar pan nad ydyn nhw'n cael eu defnyddio.

Mae lle i 4 hofrennydd ym mhob hangar yn y llun isod. Oes yna ddigon o hangars i gadw pob hofrennydd sydd yn y llun?

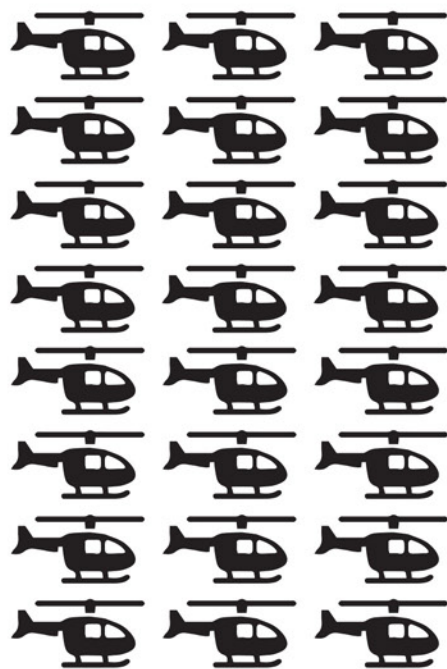
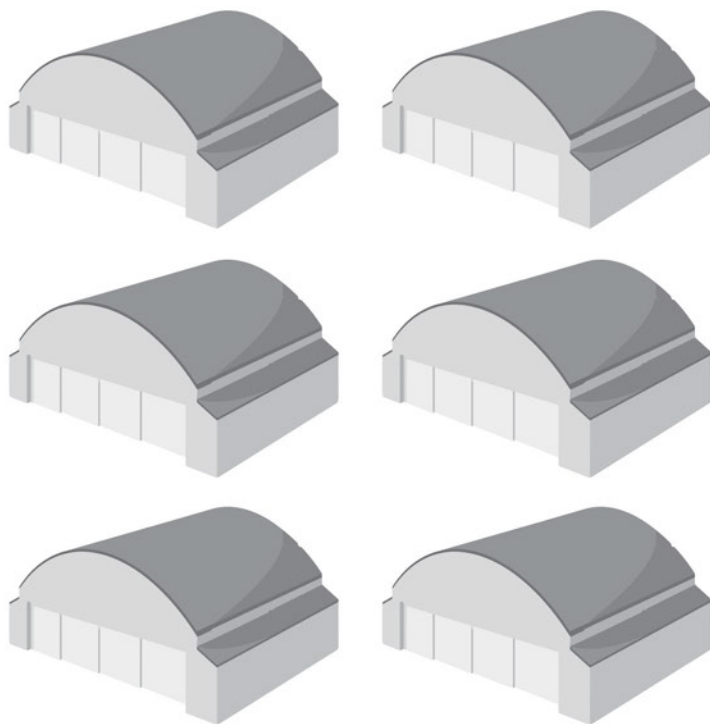

Yn y blwch hwn ysgrifennwch gyfanswm y lleoedd yn yr hangars.

Yn y blwch hwn dywedwch a oes digon o hangars ar gyfer yr hofrenyddion ('Oes' neu 'Nac oes').



COD 1

A	B	C	D	E	F	G	H	I	J	K	L	M
N	O	P	Q	R	S	T	U	V	W	X	Y	Z

N	O	P	Q	R	S	T	U	V	W	X	Y	Z
A	B	C	D	E	F	G	H	I	J	K	L	M

COD 2

A	B	C	D	E	F	G	H	I	J	K	L	M
Z	Y	X	W	V	U	T	S	R	Q	P	O	N

N	O	P	Q	R	S	T	U	V	W	X	Y	Z
M	L	K	J	I	H	G	F	E	D	C	B	A

COD 3

A	B	C	D	E	F	G	H	I	J	K	L	M
A	J	S	B	K	T	C	L	U	D	M	V	E

N	O	P	Q	R	S	T	U	V	W	X	Y	Z
N	W	F	O	X	G	P	Y	H	Q	Z	I	R

Bydd angen i chi ddefnyddio eich sgiliau i gyd i ddatrys y cod.

Defnyddiwch y cod priodol i ganfod geiriau'r RAF

COD 1 U R E P H Y R F

--	--	--	--	--	--	--	--

COD 2 G B K S L L M

--	--	--	--	--	--	--	--

COD 3 Z V M J P A

--	--	--	--	--	--	--	--

COD ? Z N B Q L S M H L M

--	--	--	--	--	--	--	--	--	--

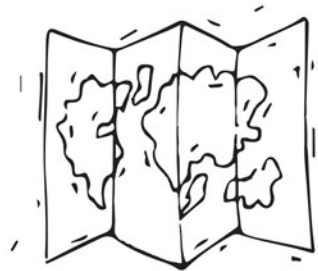

Gwneud codau

Defnyddiwch y codau i amgryptio (codio) y geiriau

⋮ COD 1 P E I L O T

--	--	--	--	--	--	--	--

⋮ COD 2 H O F R E N N Y D D

--	--	--	--	--	--	--	--	--	--

⋮ COD 3 S P I T F I R E

--	--	--	--	--	--	--	--	--	--



Codio â baneri

Semaffor



Mathemateg

Ffordd o ddanfôn negeseuon drwy ddefnyddio cod sy'n seiliedig ar leoliad y ddwy fraich neu ddwy faner yw semaffor. Mae'n ddefnyddiol iawn os ydych chi eisiau anfon neges at rywun sy'n rhy bell oddi wrthy ch i allu eich clywed.

Mae gan bob llythyren yn yr wyddor god penodol, fel y gwelwch isod

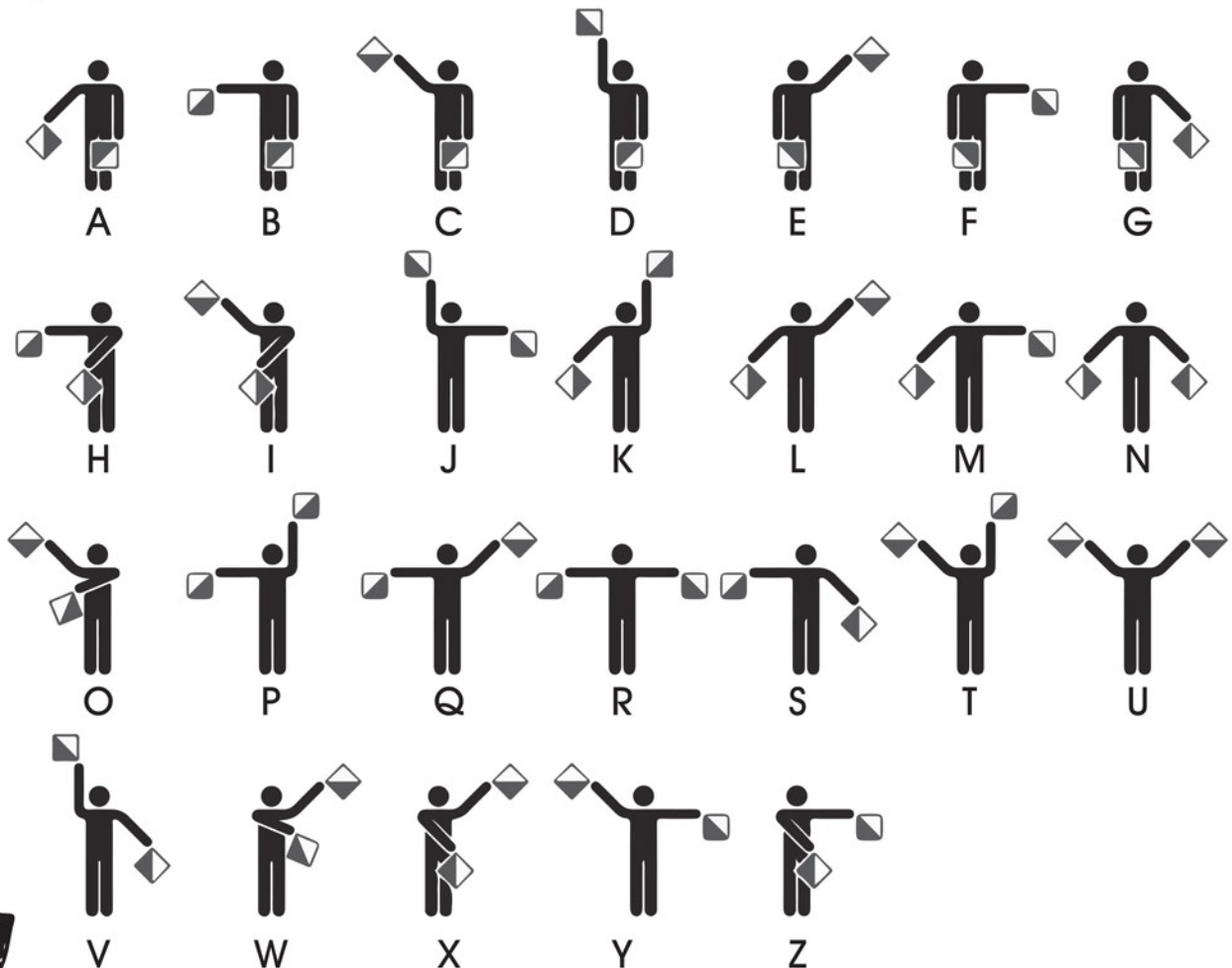

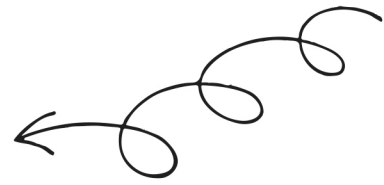

Drwy ddefnyddio'r cod semaffor,
allwch chi ddweud
beth yw'r neges? Ysgrifennwch
bob llythyren i sillafu'r neges.

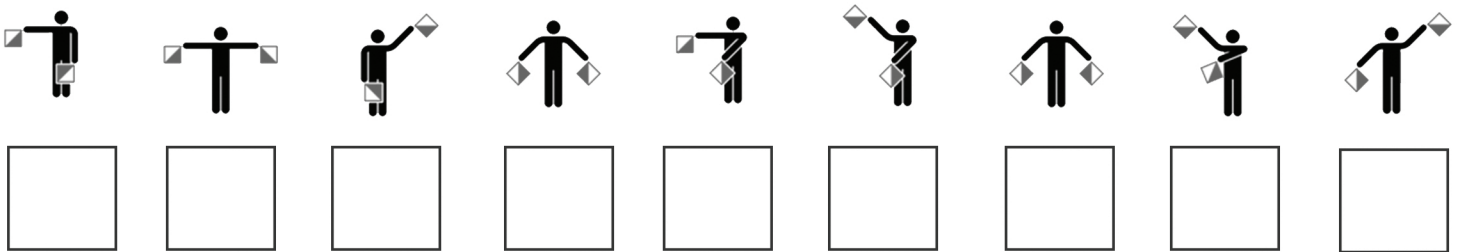
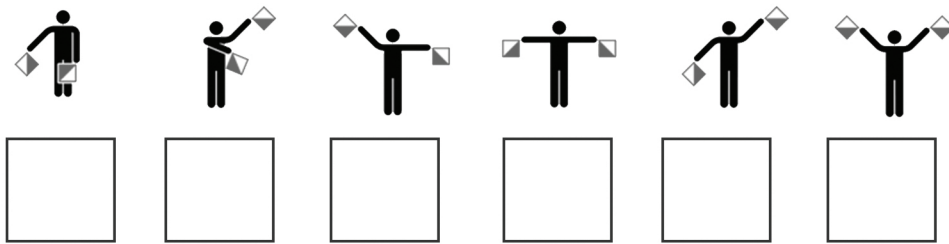
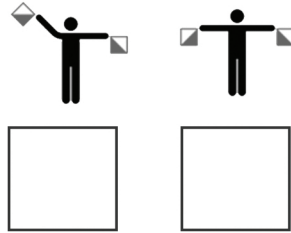



Beth sy'n Wahanol?

Mathemateg

Allwch chi weld beth sy'n wahanol yn y ddau lun?

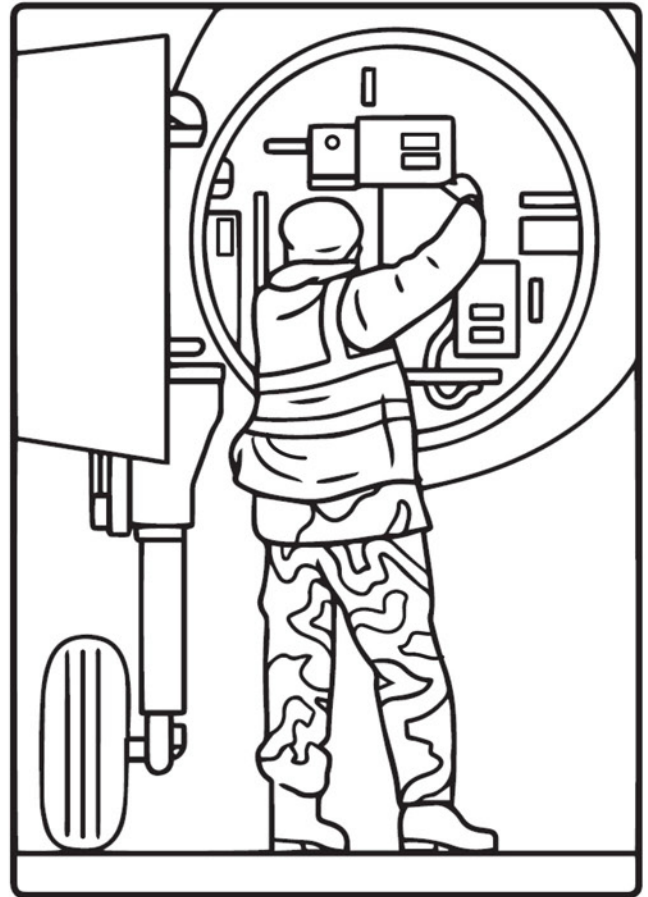
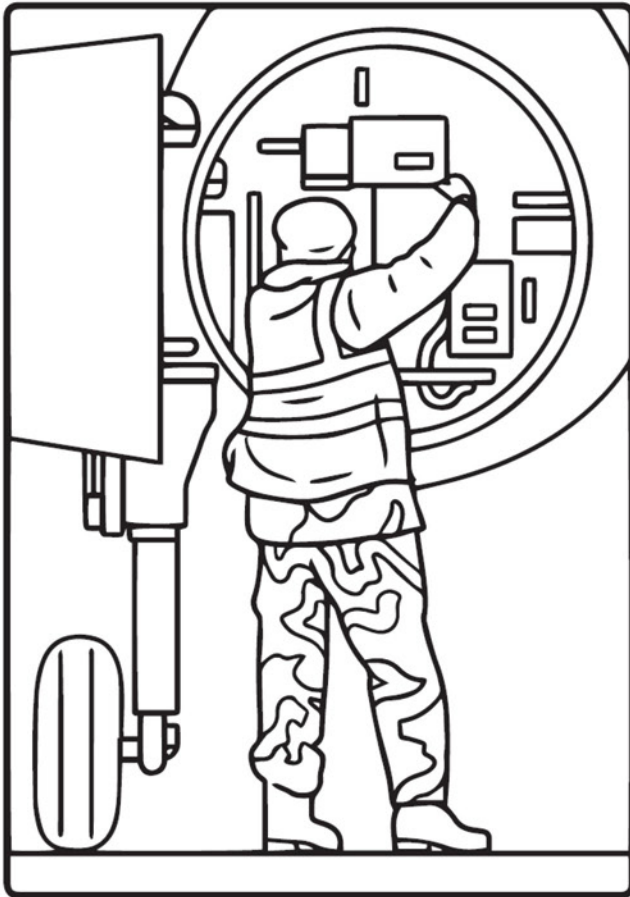

Rhowch gylch am y pethau sy'n wahanol yma.



CLIW!
Mae 6 o bethau sy'n wahanol





Mathemateg

Rhannu



Mae Penny y Peilot yn cael ei phen-blwydd ac mae hi eisiau rhannu ei chacen pen-blwydd â chynifer o bobl ag sy'n bosibl. Mae'r gacen wedi cael ei thorri'n ddarnau yn barod.

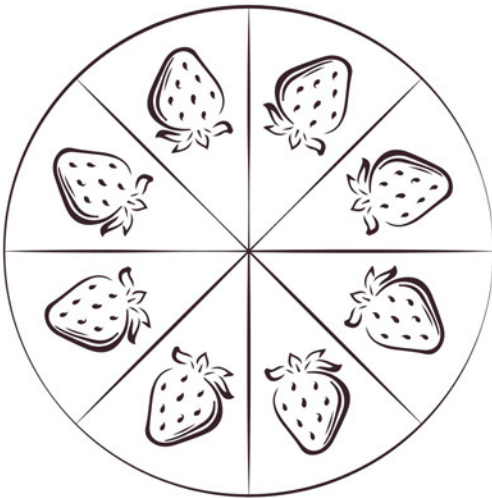

Nifer y darnau:

Nifer y bobl a all gael darn o'r gacen:

Pe bai Penny yn penderfynu rhoi dau ddarn o'r gacen i bawb, faint o bobl fyddai'n gallu cael rhywfaint o'r gacen? (cliw: bydd angen i chi ganfod faint o weithiau y gallwch chi gyfri dau ddarn o'r gacen).

Faint o weithiau allwch chi gyfri dau ddarn:

Faint o bobl allai gael dau ddarn yr un:



Beth yw ei enw?

Cymraeg

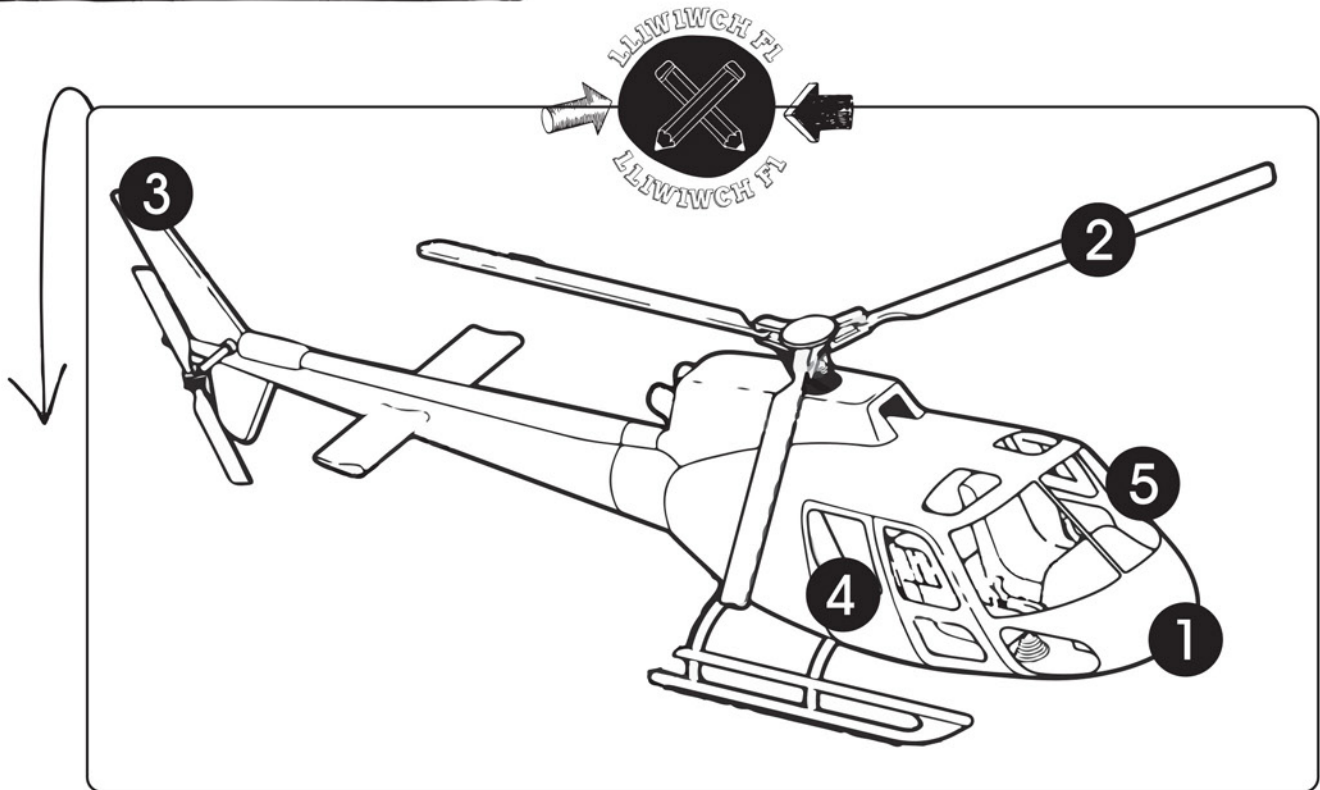

Mae Peter y Peilot eisiau i chi ei helpu i
enwi gwahanol rannau o'r hofrennydd.
Rhowch y rhif yn ymyl y gair:

- LLAFNAU/ROTORAU
- SGRÎN WYNT
- FFENESTR
- TRWYN
- CYNFFON

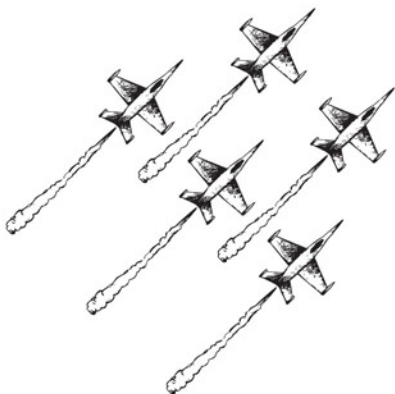



Mae Penny y Peilot angen help gennych chi!

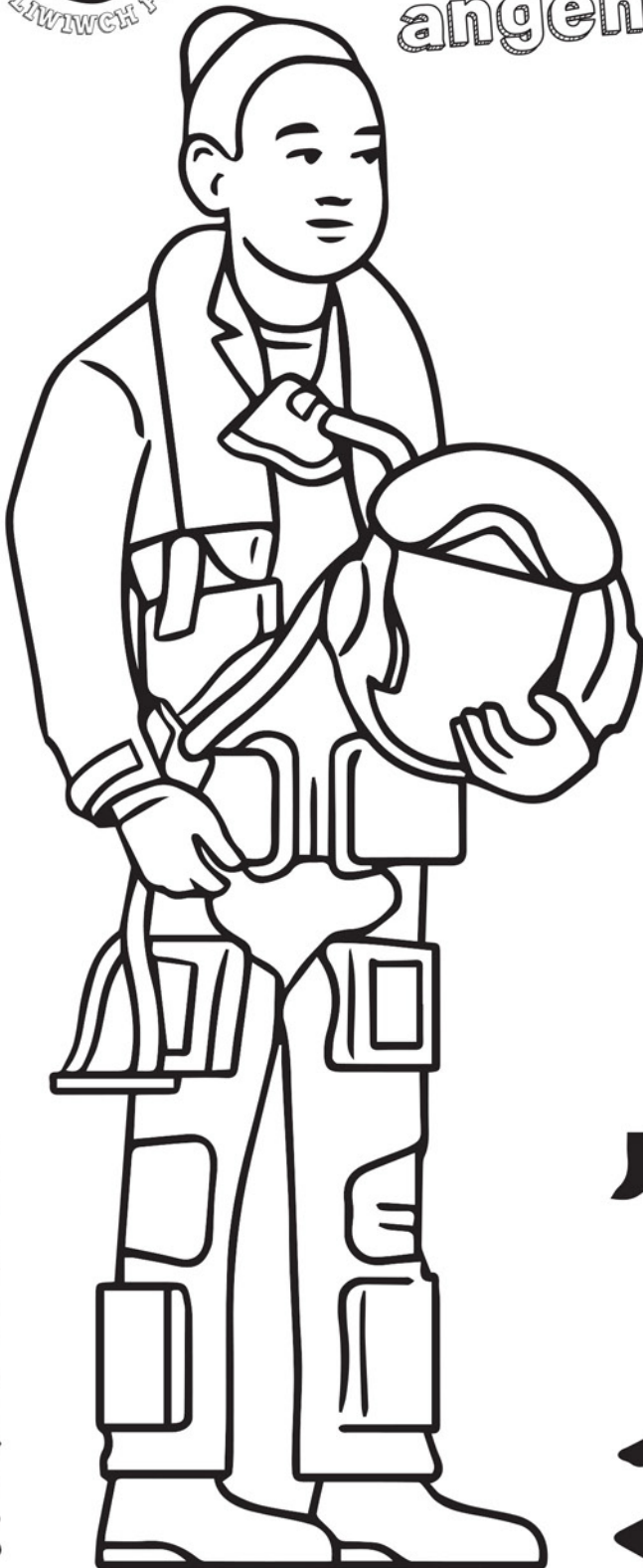

Allwch chi ddweud o'r disgrifiad, pa fath o awyren mae hi'n ei ddisgrifio?

Rhowch y llythyren gywir wrth bob awyren.

A: Cerbyd hedfan ag adenydd sefydlog.

B: Math o awyren lle mae'r egni'n cael ei gyflenwi gan rotorau

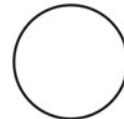

HOFRENNYDD

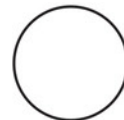

AWYREN



Wythnos brysur Penny a Peter



Mathemateg

Mae Penny y Peilot a Peter y Peilot wedi bod yn brysur iawn yr wythnos yma. Dydd Llun aeth Penny i fyny i'r awyr 3 gwaith yn ei hawyren jet. Hedfanodd Peter ddwywaith yn ei hofrennydd dydd Llun. Maen nhw wedi cwblhau'r siart ar gyfer dydd Llun (drwy liwio nifer yr awyrennau). Allwch chi gwblhau gweddill y siart iddyn nhw gan ddefnyddio'r wybodaeth maen nhw wedi ei rhoi?

10					
9					
8					
7					
6					
5					
4					
3					
2					
1					
	LLUN	MAWRTH	MERCHER	IAU	GWENER
	Penny = 3 GWAITH Peter = 2 WAITH	Penny = 2 WAITH Peter = 3 GWAITH	Penny = 4 GWAITH Peter = 2 WAITH	Penny = 1 WAITH Peter = 5 GWAITH	Penny = 5 GWAITH Peter = 3 GWAITH

Allwch chi ysgrifennu yn y blwch hwn faint o weithiau y mae Penny y Peilot wedi hedfan ei hawyren yr wythnos hon?

Allwch chi ysgrifennu yn y blwch hwn faint o weithiau y mae Peter y Peilot wedi hedfan ei hofrennydd yr wythnos hon?



Mathemateg

Beth sy'n wahanol?

Allwch chi weld beth sy'n wahanol yn y ddau lun?



Rhowch gylch am y pethau sy'n wahanol yma.



GLIW!
Mae 6 o bethau i chi chwilio amdanyn nhw

Rhagor o godio â baneri

Semaffor



Mathemateg

Bydd angen i chi edrych yn ôl ar y codau semaffor ar dudalen 20. Mae'r llythrennau i gyd yn sillafu rhywbeth sy'n gysylltiedig â'r Llu Awyr Brenhinol ond dydyn nhw ddim yn y drefn iawn! Gan ddefnyddio'r codau semaffor allwch chi ysgrifennu'r llythrennau a'u haildrefnu i sillafu'r neges?



Goleuo!



Gwyddoniaeth

Mae Peter y Peilot yn dweud ei bod hi'n bwysig iawn ei fod yn gallu gweld i ble mae'n hedfan yn ei awyren – felly mae ei goleuadau'n ddefnyddiol iawn.

Edrychwch ar y ffynonellau golau yn y llun isod a cheisiwch gyfateb y lluniau a'r geiriau.

Matshys

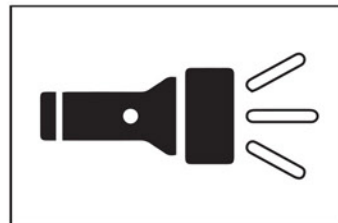

Seren



Cannwyll

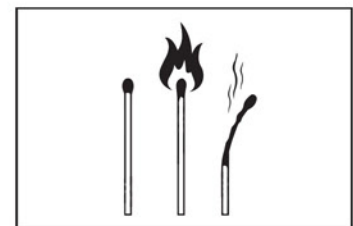

Lamp

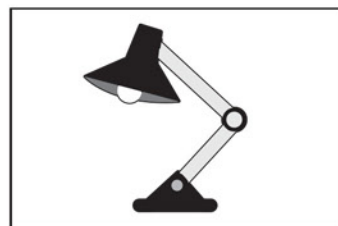

Tortsh

Tân

Bwlb golau

Pa rai ohonyn nhw sy'n defnyddio trydan i gynhyrchu golau?

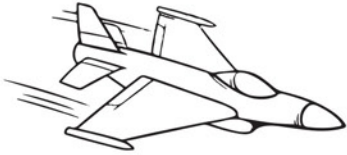

Hedfan fry



Mae Penny y Peilot angen help gennych chi!

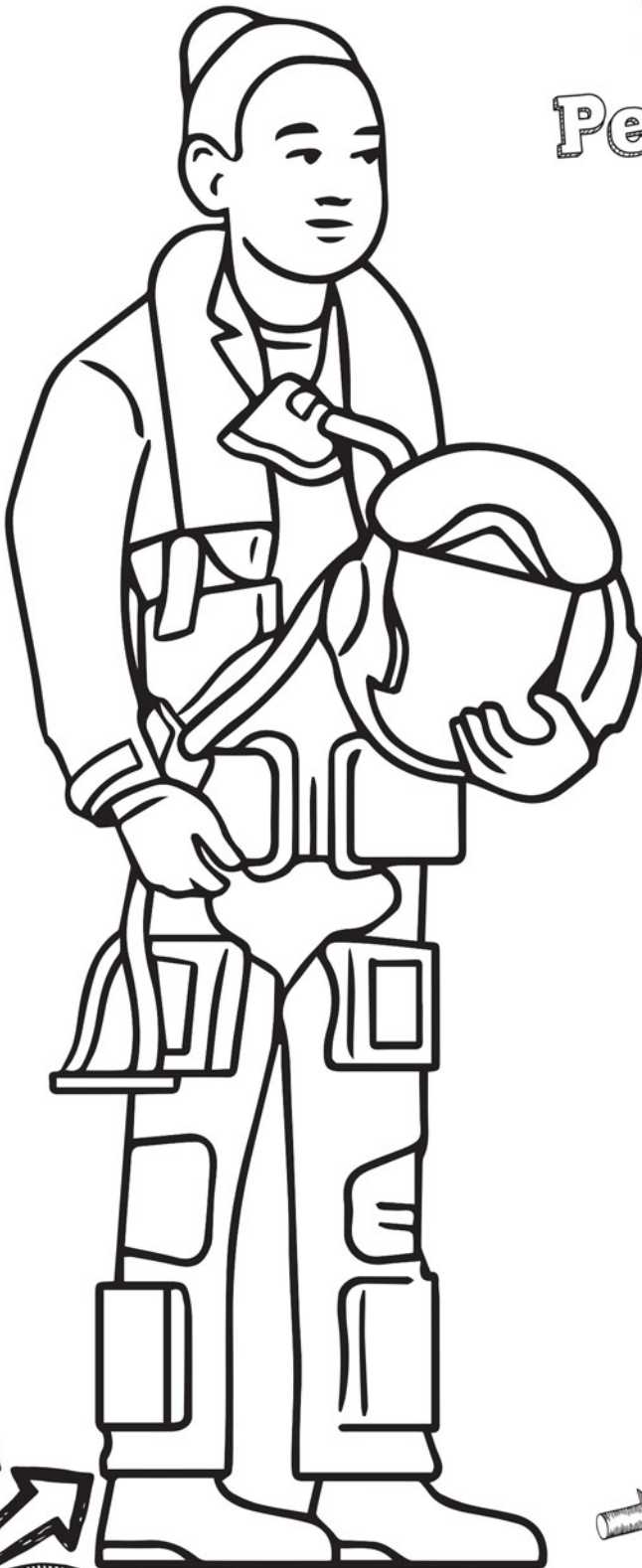













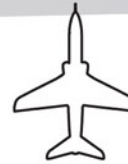











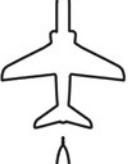









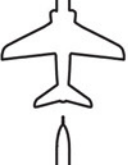









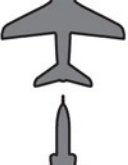

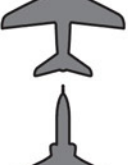

Mae angen iddi lunio siart yn dangos faint o weithiau mae hi wedi hedfan ei hawyren yn ystod yr wythnos.

Aeth i fyny yn yr awyren 3 gwaith dydd Llun, ac mae wedi cwblhau'r siart ar gyfer dydd Llun (drwy liwio nifer yr awyrennau).

Allwch chi gwblhau gweddill y siart iddi hi gan ddefnyddio'r wybodaeth mae hi wedi'i rhoi?

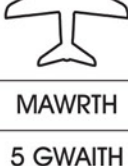

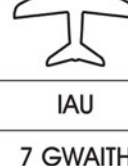
10
9
8
7
6
5
4
3
2
1

				
				
				
				
				
				
				
				
				
				
LLUN	MAWRTH	MERCHER	IAU	GWENER
3 GWAITH	5 GWAITH	2 WAITH	7 GWAITH	6 GWAITH



Ysgrifennwch yn y blwch hwn sawl gwaith y mae Penny y Pilot wedi hedfan ei hawyren yr wythnos hon?



Ffeithiau diddorol



Mae gan yr
RAF dros 50
o orsafoedd
yn y DU

Bydd yr RAF yn
100 oed ym mis
Ebrill 2018!

Awyren fwyaf yr RAF
yw'r Voyager. Mae'n
gallu cario 291 o bobl a
gall hedfan am 6,000 o
fillfiroedd ar un tanc o
danwydd!

Y ferch gyntaf i fod yn
beilot oedd Jo Salter
a ddechreuodd
hedfan awyrennau jet
i'r RAF yn 1992!



Sganiwch y cod QR hwn i weld
ein wal liwio wych sy'n dangos
100 mlynedd cyntaf yr RAF

Ewch
i www.raf.mod.uk
i gael rhagor o
wybodaeth am yr
RAF!